

冷凝控制風車變頻器 使用說明書

User's manual of Fan inverter for Condensing
temperature Control

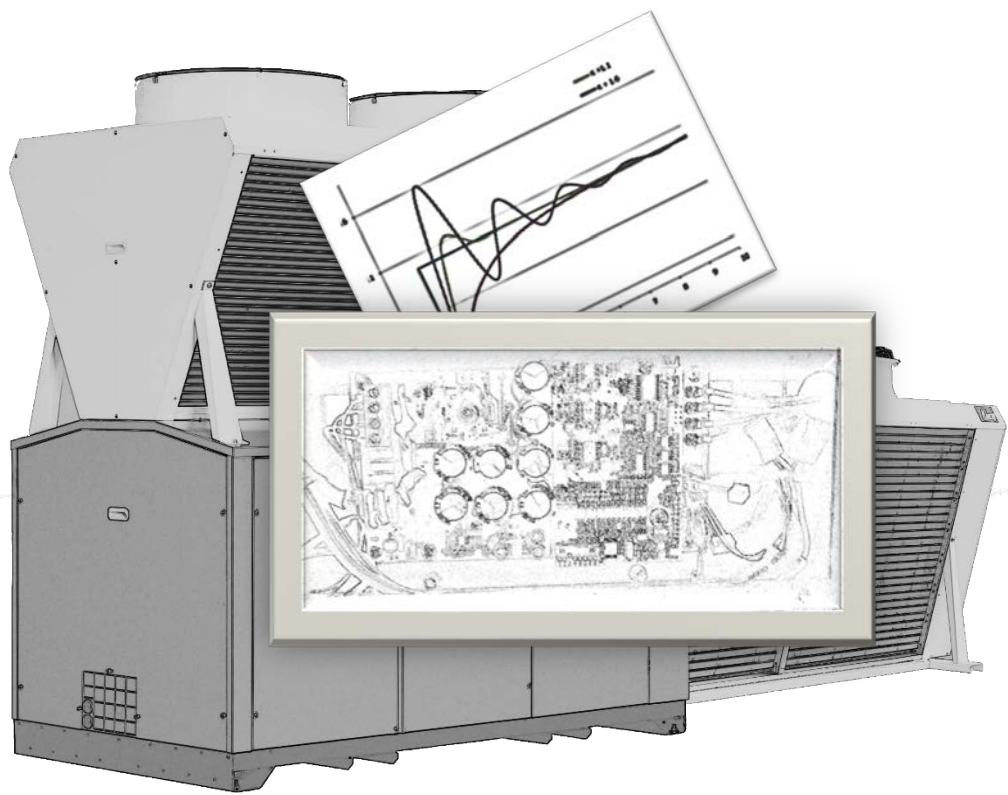



Inverter 變頻器



Manual operation interface(optional) 手動操作介面(選購)

Catalog 目錄

1 Overview 概述.....	3
1.1 About this manual 關於本說明書.....	3
2 Installation 產品安裝.....	3
2.1 Wiring for input/output power lines 輸入及輸出電源接線.....	3
2.2 Wiring for protection and control 保護及控制接線.....	4
2.3 Wiring for manual operation interface 手動操作介面接線.....	4
2.4 Deep switch setting 指撥開關設定.....	5
3 Function description 功能描述.....	5
3.1 Panel 面板.....	5
3.2 Function table screen 功能表畫面.....	7
4 Trouble shooting 故障/警告處理.....	9
4.1 Indication light 指示燈定義.....	8
4.2 Error code and trouble shooting 故障定義及處理.....	10
4.3 Alarm message 告警定義.....	11
4.4 Miscellaneous 其他.....	11
5 Tips for operation 使用注意事項.....	12

1 Overview

1 概述

1.1 About this manual

1.1 關於本說明書

This manual introduces how to use condensing fan motor inverter correctly. Must read the manual carefully before installation, wiring, operation, maintenance and check.

本說明書介紹了如何正確使用本產品，在使用（安裝、接線、運轉、維護、檢查等）之前，請務必認真閱讀本說明書。

This product is designed as an interface for manual operation, display driver information and setting parameters for condensing fan motor inverter.

本產品為風車驅動器專用的手動操作介面，用來顯示驅動器資訊，以及設定參數。

2 Installation

2 產品安裝

Read the interface diagram and instruction very carefully before wiring. And correctly connect necessary interface based on requirement.

接線前，請仔細閱讀介面示意圖及說明，並根據實際需要，正確地連接所需介面。

2.1 Wiring for input/output power lines:

2.1 輸入及輸出電源接線：

Please make sure system grounded correctly to avoid interference!

使用變頻器時系統務必正確接地，以避免干擾！

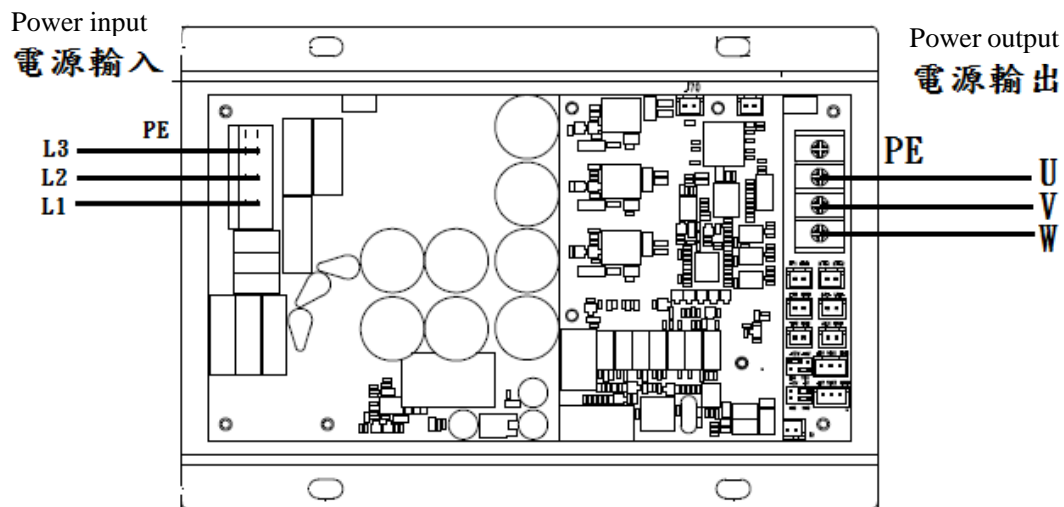

Note: The power line output U,V,W must match the fan motor wiring.

注意：電源輸出 U.V.W，需與風車搭配

2.2. Wiring

for protection and control:

2.2 保護及控制接線：

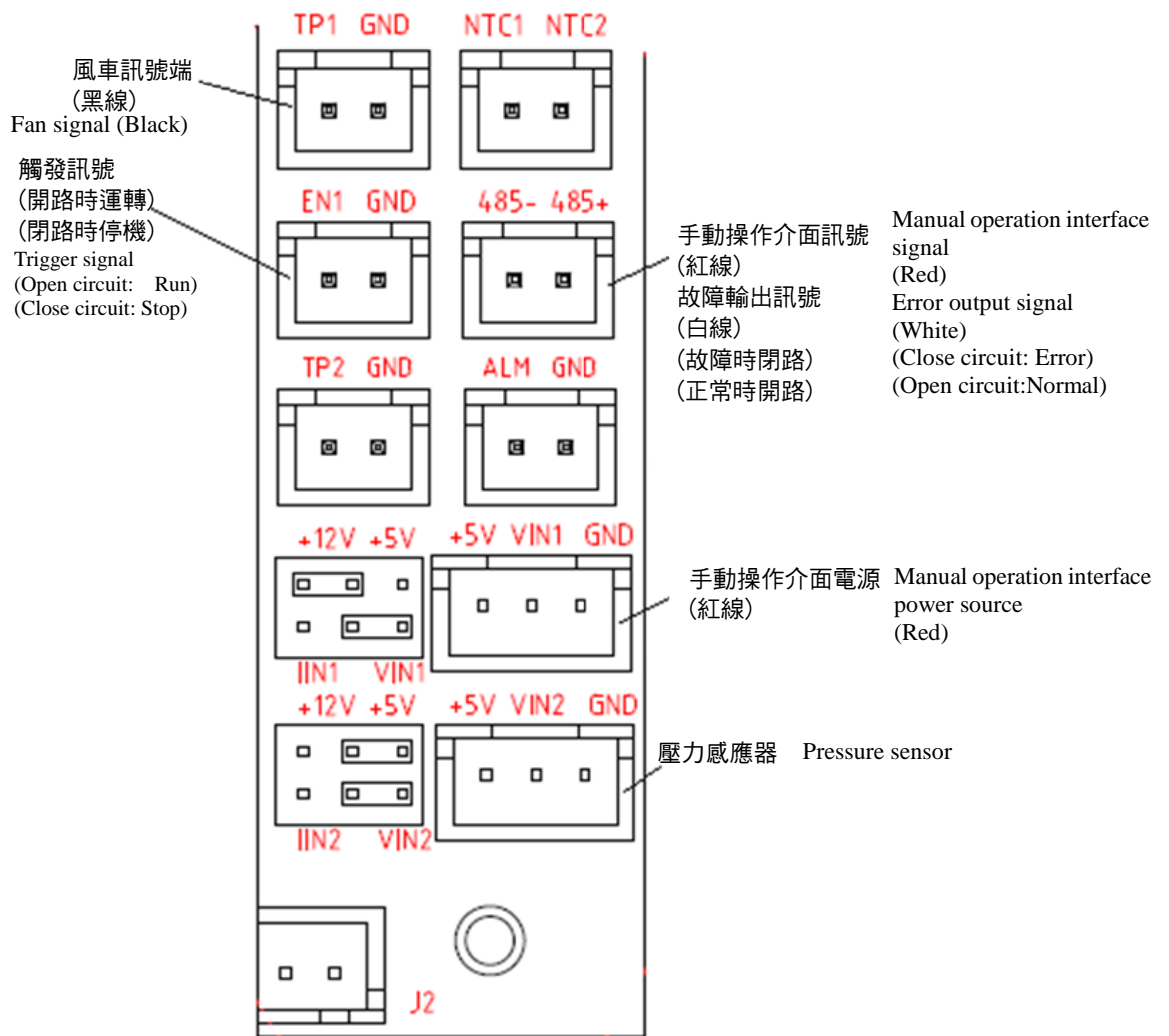

Note: All are dry contacts.

注意：所有的接點皆為乾接點。

2.3 Wiring for manual operation interface(optional):

2.3 手動操作介面(另購)接線：

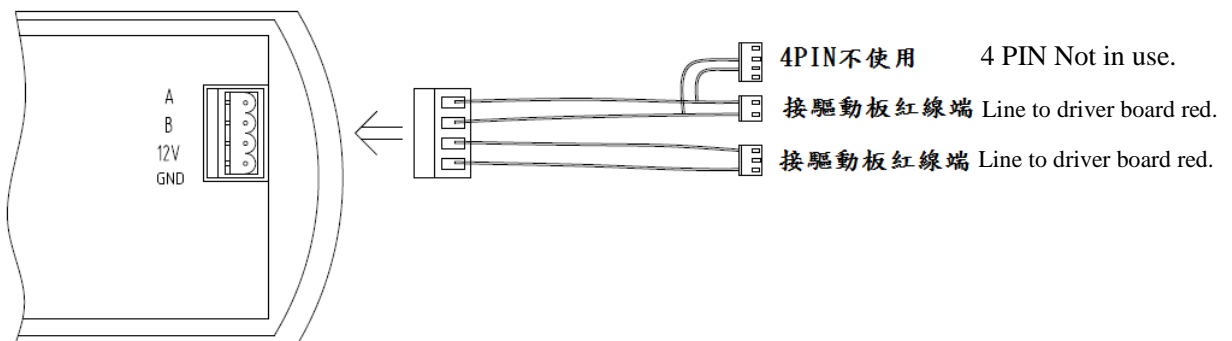
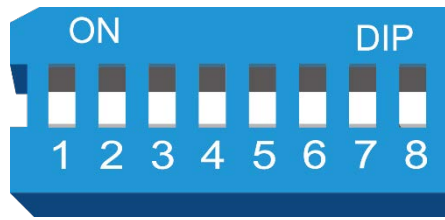

Fig. 2.1 Back connection diagram 圖 2-1 背面接線示意圖

2.4 Deep switch setting

2.4 指撥開關設定



1	TP1 TP2 保護輸入狀態 TP1 TP2 Protection input status	OFF	設定斷開時故障 Set opened as error
		ON	設定閉合時故障 Set closed as error
2	風車數量 Fan set quantity	OFF	TP1 有效 Only effect on fan set 1
		ON	TP1 TP2 有效 Effect both on fan set 1 & 2
5-7	保留 Reserved		
8	運轉模式 Operation mode	OFF	正常運轉模式 Normal operation mode
		ON	手動操作介面模式 Manual operation interface mode

3	4	電源選擇 Power source selection
OFF	OFF	380V 50HZ
ON	OFF	220V 50/60HZ
OFF	ON	400V 50/60HZ
ON	ON	460V 50/60HZ

Note: Before using manual operation interface, please set operation mode to manual operation interface mode; when not use the manual operation interface, please set back to normal operation mode. Operation mode only affects the communication function, will not have effects on any function of driver.

註：使用手動操作介面之前，請務必將驅動器運轉模式修改成手動操作介面方式，不使用手動操作介面時，請恢復為正常運轉模式。運轉模式僅影響通訊功能，不對驅動器的其他功能造成任何影響。

3. Function description

3 功能描述

3.1 Panel

3.1 面板

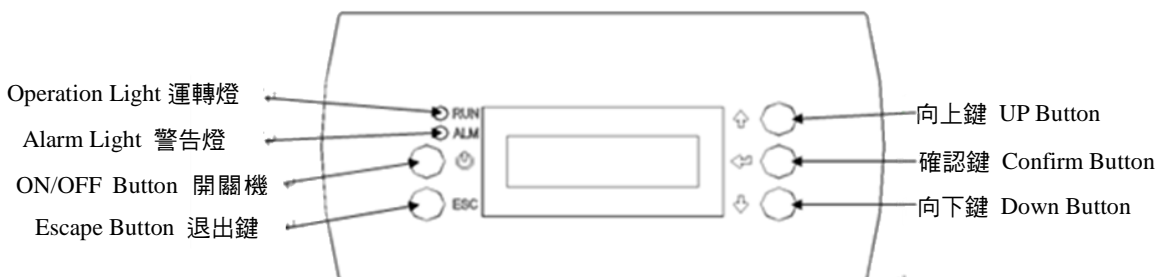

Table 3-1 Light/Button Description 表格 3-1 燈號/按鍵說明

燈號/按鍵 Light/Button	說明 Description
運轉燈 Operation light	常亮，表示運轉狀態；長滅，表示停機狀態 Light on: Running; Light off: Stop
警告燈 Alarm light	常亮，機器處於故障狀態，輸出關閉；長滅，表示無故障 Light on: Machine is error, no output; Light off: No error
開關機鍵 ON/OFF Button	開關手動操作介面 Turn ON/OFF manual operation interface
退出鍵 Escape Button	退出編輯模式，或者返回上一層功能表 Exit editing mode or return to previous layer.
向上鍵 UP Button	參數編輯模式時，按向上鍵，參數值增加； 功能表畫面，按向上鍵，回到同層功能表的前一個主畫面，按向上鍵，回到前一個顯示參數 In parameter editing, press UP button to increase value. In Function screen, press UP button to back to previous function of same layer. In main screen, press UP button to back to previous parameter.
確認鍵 Confirm Button	參數編輯模式時，按確認按鍵，確認參數修改 功能表畫面，按確認鍵，進入下一功能表或者進入參數編輯模式 主畫面，按確認鍵，進入功能表畫面 In parameter editing, press Confirm button to set value. In Function screen, press Confirm button to enter function table or enter parameter editing mode. In main screen, press Confirm button to enter function table screen.
向下鍵 Down Button	參數編輯模式時，按向下鍵，參數值減小； 功能表畫面，按向下按，回到同層功能表的後一個主畫面，按向下鍵，回到後一個顯示參數 In parameter editing, press DOWN button to decrease value. In Function screen, press DOWN button to back to next function of same layer. In main screen, press DOWN button to back to next parameter.

After connecting to power, "Connecting..." will appear on the screen. It means the manual operation interface is connecting to driver. If connects successfully, the manual operation interface will show the main screen. If keeps on showing "Connecting...", it could be an error between manual operation interface and driver. Main screen will show the following information: operation mode, current speed, pressure and temperature. Press Confirm button to enter function table screen.

送電後，手動操作介面畫面顯示“正在連接中...”，表示手動操作介面和驅動器正在連接，連接成功後，手動操作介面顯示主畫面。如果畫面一直顯示“正在連接中...”表示手動操作介面和驅動器通訊故障
主畫面顯示的內容包括：運轉狀態、當前轉速、壓力值和溫度值。
按確認按鍵進入功能表畫面。

3.2 Function table screen

3.2 功能表畫面

Structure of function table is shown below:

功能表結構如下所示：

Table 3-2 Structure of function table 表格 3-2 功能表結構

第1層 First layer	第2層 Second layer	第3層 Third layer	說明 Description
控制/設定 Control/Setting			
	參數設定 Parameter Setting		
		語言 Language	English 繁體中文 簡體中文 English Traditional Chinese Simplified Chinese
		起始轉速 Starting Speed	起始轉速，按額定轉速的百分比設定 Starting Speed, based on percentage of rating speed.
		最小轉速 Min. Speed	出廠設定值 20%。注意須配合馬達最低啟動轉速。 Default value 20% Must meet the min. starting speed of fan motor.
		控制壓力點 Controlled Pressure	出廠設定值 20 bar Default value 20 bar
		控制壓力差 Controlled pressure difference	出廠設定值 0.5 bar Default value 0.5 bar
		感測器故障轉速 Speed for sensor error	壓力感測器故障時的轉速百分比預設 90% This value is for fan motor while sensor error. Default value 20%
			建議客戶僅修改上列數值，其餘數值修改可能會造成系統錯誤!! For customer, change above parameters only. Changing other parameters could lead to system error!!
		PI 控制 Kp PI Control Kp	比例係數 Kp 出廠設定值 1024(不建議修改) Proportional factor Kp. Default value 1024.(Do not modify!)
		PI 控制 Ki PI Control Ki	積分係數 Ki 出廠設定值 10(不建議修改) Proportional factor Ki. Default value 10.(Do not modify!)
		感測器類型 Sensor type	電壓型/電流型,預設電壓型 Voltage type/ Current type. Default Voltage type.
		最大壓力 Max. Pressure	出廠設定值 42 bar Default value 42 bar
		最大壓力/電壓 Max. P/Voltage	出廠設定值 4.5 V Default value 4.5 V
		最小壓力 Min. Pressure	出廠設定值 0bar Default value 0 bar
		最小壓力/電壓 Min. P/Voltage	出廠設定值 0.5v Default value 0.5 V
	進階 Advanced		
		清除所有故障 Clear all errors	
		參數恢復預設值 Restore to Default values	
	暫存器設定 Program control register Setting		所有可以通過通訊設定的參數，也可以在本功能表中設定。具體請參見通訊協定 All parameters set by communication port could be set in this function table. For detail information please refer to Communications protocol.
		暫存器位址 Program control	暫存器位址 Program control register address

第1層 First layer	第2層 Second layer	第3層 Third layer	說明 Description
		register address	
		暫存器值 Program control register value	暫存器的協議值 Program control register protocol value
查看訊息 Check message			
	查看警告訊息 Check alarm message		
		FID:01	通訊故障 Communication Error
		FID:02	環境溫度過高 Surrounding temperature is too high.
		FID:03	模組溫度過高 Module temperature is too high.
		FID:04	風車 1 溫度過高 Fan 1 temperature is too high.
		FID:05	風車 2 溫度過高 Fan 2 temperature is too high.
		FID:06	風車溫度過高鎖定 Locked due to high fan motor temperature.
		FID:07	來源電壓不足 Power source voltage is too low.
		FID:08	來源電壓過高 Power source voltage is too high.
		FID:09	內部通訊故障 Internal communication error.
		FID:11	硬體過電流 Hardware is over current.
		FID:12	EEPROM 故障 EEPROM is out of order.
		FID:13	環境溫度感測器故障 Environment temperature sensor is out of order.
		FID:14	模組溫度感測器故障 Module temperature sensor is out of order.
		FID:15	外部溫度感測器故障 External temperature sensor is out of order.
		FID:17	電流檢測電路故障 Current detect circuit is out of order.
	查看故障資訊 Check error information		
		WID:01	外部溫度感測器故障 External temperature sensor is out of order
		WID:02	超載 Overload
		WID:03	類比量故障 Analog quantity is out of order.
		WID:04	類比量下限故障 Low limit of analog quantity is out of order.
		WID:05	類比量上限故障 Up limit of analog quantity is out of order.
		WID:06	環境溫度過高 Surrounding temperature is too high.
		WID:07	風扇故障 Fan is out of order.
		WID:08	通訊逾時 Communication timeout.
		WID:09	EEPROM 故障 EEPROM is out of order.
		WID:10	溫度過高降頻 Temperature is too high, lower frequency.
	查看機器資訊 Check machine information		

By using UP, DOWN/CONFIRM and ESCAPE buttons can switch between different function layers. For the last function layer, use CONFIRM button to enter editing mode or execute that function. In parameter editing mode, the edited parameter will be highlighted, use UP/DOWN button to change the setting value. Press and hold the button will increase the value change speed. After modifying the value, press CONFIRM button to accept the new value and exit editing mode; if press ESCAPE button instead of CONFIRM button, the changed value will be discarded and exit editing mode.

利用上下按鍵/確認、退出鍵，可以在各層功能表之間切換。對於最末層的功能表，可以利用確認鍵，進入參數編輯模式或者執行功能表對應的功能。在參數編輯模式，被編輯的參數反色顯示，通過向上/向下鍵更改設定值，長按向上/向下鍵，可以加快設定值的增減速度。修改後，按確認鍵，則確認參數修改並退出模式；按退出鍵，則放棄參數修改並直接退出編輯模式。

4. Trouble shooting

In this article, error is defined as driver stops outputting under some condition(s), driver can be restarted only when problem has been solved. Alarm is defined as driver still works when the condition happens. It will not change the running condition of driver, just a warning message to user.

4. 故障/警告處理

本文檔所定義的故障，是指發生該種狀態時，驅動器停止輸出，只有待該種狀態消除後，驅動器才能再次啟動；本文件所定義的警告，是指發生該種狀態時，不改變驅動器當前運轉狀態，僅用以提示使用者。

4.1 Indication light

You may check the driver status by indication lights. These indication lights locate on the control board. Their position is shown below.

4.1 指示燈定義

本驅動器可以通過指示燈來指示驅動器的當前狀態。驅動器狀態指示燈在控制板上，具體位置如下

Fig. 4-1 Positions of indication lights

圖 4-2 指示燈位置

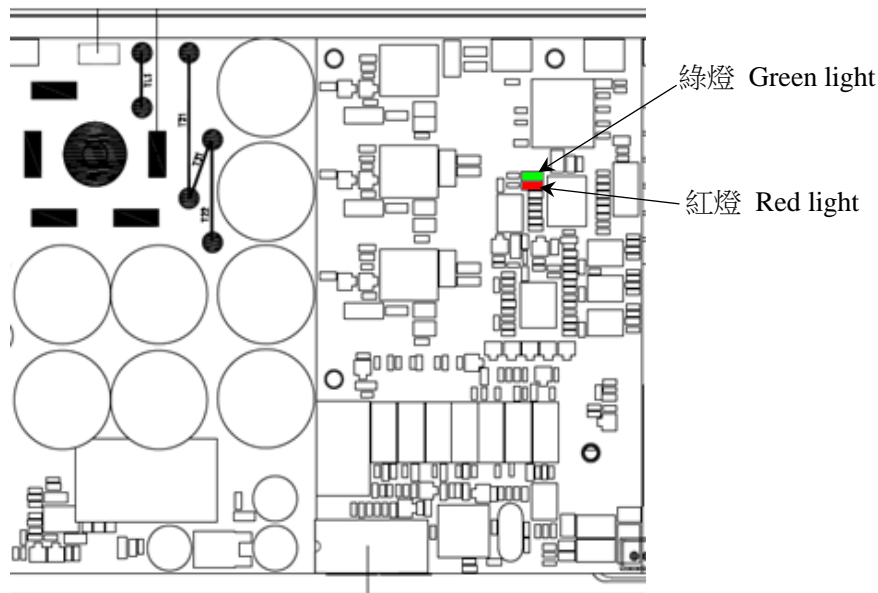

Fig. 4-2 Status of driver 圖 4-3 驅動器狀態

驅動器狀態 Driver status	綠燈 Green light	紅燈 Red light
驅動器待機 Driver standby	閃爍 (亮 0.25s, 滅 0.25s) Blinking(on 0.25s, off 0.25s)	常滅 Light off
驅動器故障 Driver error	常滅 Light off	閃爍 N 次 (亮 0.25s, 滅 0.25s), 然後滅 2s, 以此重複。(N 為故障號, 詳見故障信號定義) Blink N times(on 0.25s, off 0.25s), then off for 2 seconds, keeps on repeat like this. (N is the error code number, check the error trouble shooting table.)
驅動器告警 Driver alarm	常亮 Light on	閃爍 N 次 (亮 0.25s, 滅 0.25s), 然後滅 2s, 以此重複。(N 為告警號, 詳見告警信號定義) Blink N times(on 0.25s, off 0.25s), then off for 2 seconds, keeps on repeat like this. (N is the alarm code number, check the alarm message table.)
驅動器正常運轉 Driver running	閃爍 (亮 0.25s, 滅 0.25s) 綠燈亮時, 紅燈滅 Blinking(on 0.25s, off 0.25s) When green light is on, the red light is off.	閃爍 (滅 0.25s, 亮 0.25s) 紅燈亮時, 綠燈滅 Blinking(off 0.25s, on 0.25s) When red light is on, the green light is off.

4.2 Error code and trouble shooting

4.2 故障定義及處理

Table 4-1 Error code and trouble shooting

表格 4-1 故障定義

故障紅燈 閃爍次數 Blinking times of red light	故障類別 Error	說明 Action
1	通訊故障 Communication error	通訊恢復後自動消除 Automatically distinguished when communication is back to normal.
2	環境溫度過高 Environment temperature is too high.	
3	模組溫度過高 Module temperature is too high.	
4	風車 1 溫度過高 Fan 1 temperature is too high.	
5	風車 2 溫度過高 Fan 2 temperature is too high.	
6	風車溫度過高鎖定 Locked due to high fan motor temperature.	1 小時內 2 次風車溫度過高則鎖定, 需斷電才能消除 If happens 2 times of fan temperature overheat during 1 hours, needs to power off to eliminate this error.
7	來源電壓過低 Power source voltage is too low.	
8	來源電壓過高 Power source voltage is too high.	
9	內部通訊故障 Internal communication error.	
10	NA	
11	硬體過電流 Hardware is over current.	電源關閉才能消除 Power off to reset.

故障紅燈 閃爍次數 Blinking times of red light	故障類別 Error	說明 Action
12	EEPROM 故障 EPROM is out of order.	
13	環境溫度感測器故障 Environment temperature sensor is out of order.	
14	模組溫度感測器故障 Module temperature sensor is out of order.	
15	外部溫度感測器故障 External temperature sensor is out of order.	
16	NA	
17	電流檢測電路故障 Current detect circuit is out of order.	電源關閉才能消除 Power off to reset.

4.3 Alarm message

4.3 警告定義

Table 4-2 Alarm message

表格 4-3 警告定義

	警告類別 Alarm message	說明 Action
1	外部溫度感測器故障 External temperature sensor is out of order	
2	超載 Overload	
3	類比量故障 Analog quantity is out of order.	
4	類比量下限故障 Low limit of analog quantity is out of order.	
5	類比量上限故障 Up limit of analog quantity is out of order.	
6	環境溫度過高 Surrounding temperature is too high.	
7	風扇故障 Fan is out of order.	
8	通訊逾時 Communication timeout.	
9	EEPROM 故障 EEPROM is out of order.	
10	溫度過高降頻 Temperature is too high, lower frequency.	

4.4 Miscellaneous

4.4 其他

If do not press any button for 10 seconds, the screen will turn off automatically. Press any key to turn on screen.

如果超過 10 秒鐘沒有按下面板按鍵，則面板自動關閉顯示，可以按任意鍵打開顯示。

5. Tips for operation

1. Please follow the instruction to connect this product correctly. Wrong wiring will cause damage or burn down to this product, electrical machine and related devices.
2. Do not turn on and turn off the driver frequently. **Have to wait for 3 minutes to power on after turn off.**
3. Avoid static electric shock during wiring driver. Especial soldering operation, the soldering iron must be grounded, otherwise could bring damage to parts.
4. Do not bend or drop down the control board.
5. When connecting power to this product terminals, must prevent dusts accumulate on the connecting part or cause the terminals deforming. If connection is bad, might lead to overheat and fire.
6. Have to consider the electric capacity and heat resistance for selecting wire, connectors and terminals, please obey the local electric rule for select the parts. Please do not use the parts with mechanical contactor such as switch and relay.
7. Do not break the skin of electrical wires during installation and connection. There will be potential risk of electric shock, short circuit, electric mechanism burn down and catch fire.
8. **Sever injury hazard! Do not place hand(s) or finger(s) into the rotating part of fan when power is on.** Before plug in or take out connector of this product, please turn off the power and wait for fan stop rotating.
9. For checking external affection such as noise, voltage impulse, instantaneous power failure, malfunction by static electric and circuit breakdown, must take power source into consideration.
10. The electric mechanism installation of the whole system must be done correctly. If not, will lead to noise, vibration and shortening the life of bearings.
11. Do not hold the wires and shaft part of electric mechanism directly while operating.
12. Do not disassembly this product. If so, the safety and performance might be affected, warranty will be void. There is high voltage inside electric mechanism and driver, please be careful when operates with cover opened.
13. **Do not use this product in corrosive gas environment (such as H₂S, SO₂, NO₂.....), hazard gas environment and outgassing hazard gas material (such as organic silicon, cyano, fumalin and phenolic related material).** Please contact us before if your environment is with corrosive or hazard gas. Otherwise will shorten product life cycle.
14. Do not store this product in corrosive/hazard gas environment described above and must meet the storage condition of this product, especially in long term storage.
15. **Do pay attention for static electric protection** while install/remove electric mechanism or driver.

5. 使用注意事項

1. 請按照正確的方式連接本產品的連接導線。連接錯誤會造成本產品和電機以及週邊器件損壞和燒毀。
2. 驅動器不能頻繁送電，驅動器需斷電三分鐘之後才能送電。
3. 連接驅動器導線時，請注意靜電防護，尤其焊接操作，電烙鐵需要可靠接地，否則容易造成器件損傷。
4. 控制板不得彎曲和跌落。
5. 在向本產品電源端子上接線時，注意不要附著灰塵或使端子產生變形。如果線連接不好，可能因異常發熱而造成火災。
6. 使用導線、連接器、接線端子等零部件時，要充分考慮電氣容量和耐熱性，使用符合規格的產品。請不要使用開關、繼電器等機械性觸點。
7. 進行本產品的安裝、接線等作業時，應注意不要劃傷電機的導線。因為有時會造成觸電或電機燒壞、起火等事故。
8. 接通電源後，手或手指絕對不要接觸風車旋轉部位，以免受傷，操作人員務必要遵守。在對本產品接插或拔出連接器時，請務必關斷電源，待風車旋轉停止後再進行操作。
9. 對於雜訊、衝擊電壓、瞬間停電、靜電造成的誤動作、電路擊穿、輻射雜音等對外部產生的影響，需要和電源配套一起進行確認。
10. 在整體設備上應按正確的電機安裝方式進行安裝，安裝方式不正確往會引起噪音和振動，軸承壽命將會縮短。
11. 操作時絕對不要直接拿著電機的導線、軸等部位。
12. 請不要自行拆開產品，因為拆開後無法保證其安全性和性能。電機及驅動器內部帶有高壓，打開操作時請注意安全。
13. 請不要在腐蝕性氣體（H₂S、SO₂、NO₂等）、有害氣體的環境中以及會發生有害氣體的物質（特別是有機矽系列、氰基系列、福馬林系列、酚醛系列物質）等場所使用本產品。使用時請事前與我們聯繫，如果在整機中也存在上述物質的話，應事先進行充分的確認，否則會使產品生銹或縮短壽命。
14. 保管時應避免放置在上述有腐蝕性氣體、有害氣體的環境中以及超過規格書記載的保管條件範圍中，特別是長期庫存品更應注意。
15. 安裝和拆下電機或驅動器時，請注意靜電防護。